

# The CraneKit for Crane Builders

03.2013

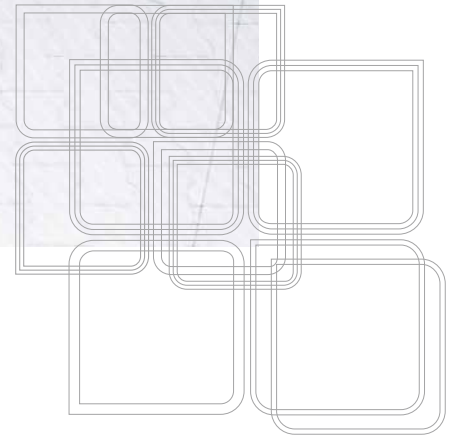
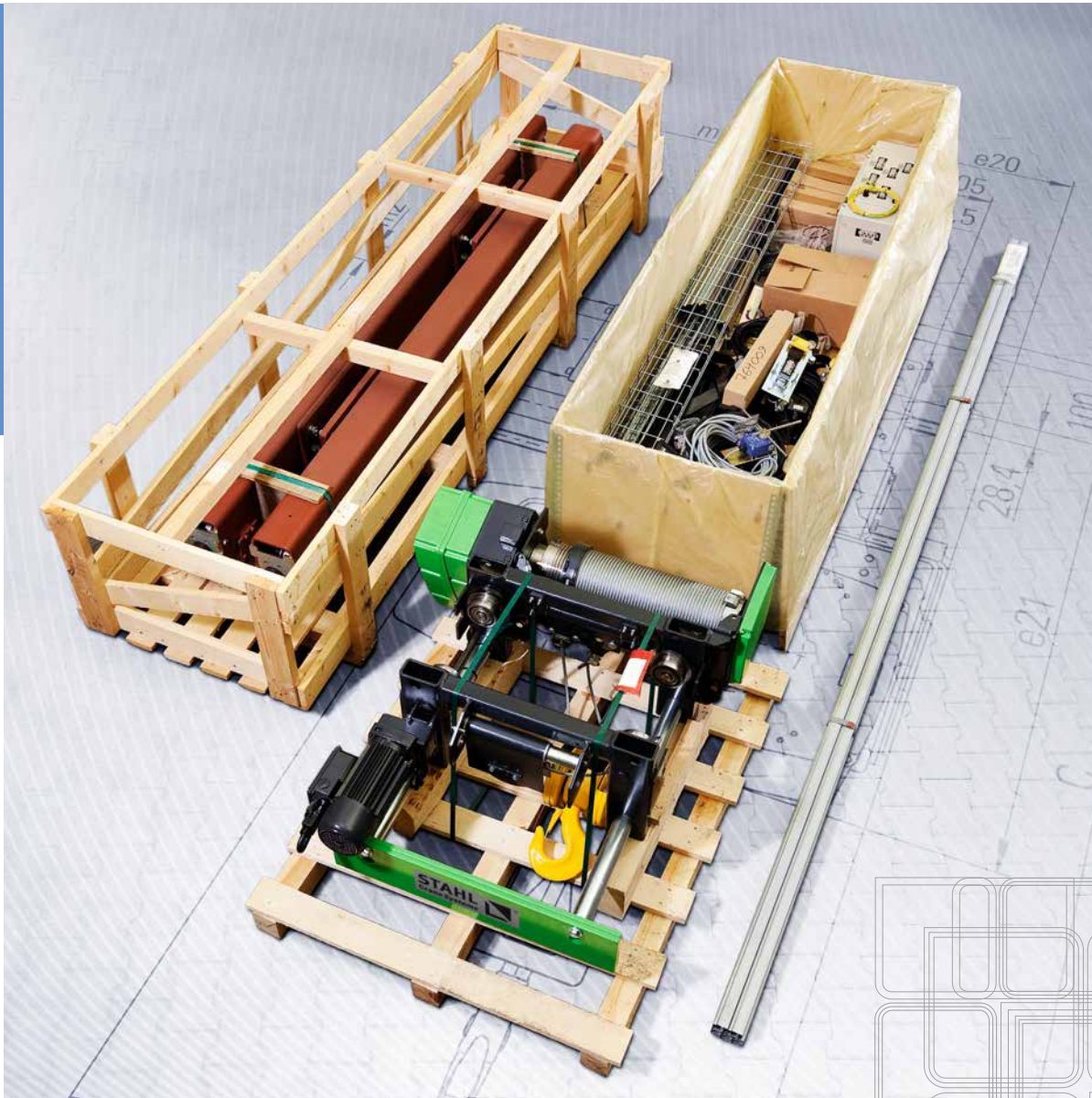

*Partner of Experts*

**STAHL**  
CraneSystems ®

# The CraneKit

STAHL CraneSystems' CraneKit creates a new opportunity for crane manufacturers around the world to complete orders efficiently and cost-effectively while keeping the planning outlay manageable. Supported by the expertise of one of the largest manufacturers of hoists and crane components at all times. For even during the development phase you as crane manufacturer can call on our engineering team to assist you. STAHL CraneSystems produces the hoist, the components and equipment, tests everything and then preassembles and delivers the completed CraneKit. Customer advisory services, planning, building the crane system, service and spare parts supply stay in your hands, in the vicinity of your customers.



## The CraneGuide

The CraneGuide planning software makes the clear, simple configuration of the crane system, time-saving preparation of quotations and problem-free ordering particularly efficient.

## The product portfolio

Choose from the world's most comprehensive range of lifting, drive and control technology products. Even off-standard and customised solutions are possible. All components are manufactured in modern series production and are subjected to our strict quality assurance management.

## Erection

Erecting the crane system follows the user-friendly plug-and-play principle; assuming naturally that this is technically possible and meets the project requirements. All components are supplied pre-assembled and wired, and relatively little time is required to set them up.

## A capable partner

Profit from our knowledge acquired in over 130 years in lifting and crane technology and explosion protection. We support you during the whole period of our cooperation.

## The facts

- All components are tested before delivery
- Plug and play: pre-fabricated cables as far as is technically possible
- All connections are clearly labelled
- Cable trolleys are pre-assembled
- Convenient planning and ordering using the CraneGuide software
- Engineering support from STAHL CraneSystems' experts
- Factory service department for difficult jobs
- Supplier of explosion-protected CraneKits all around the world

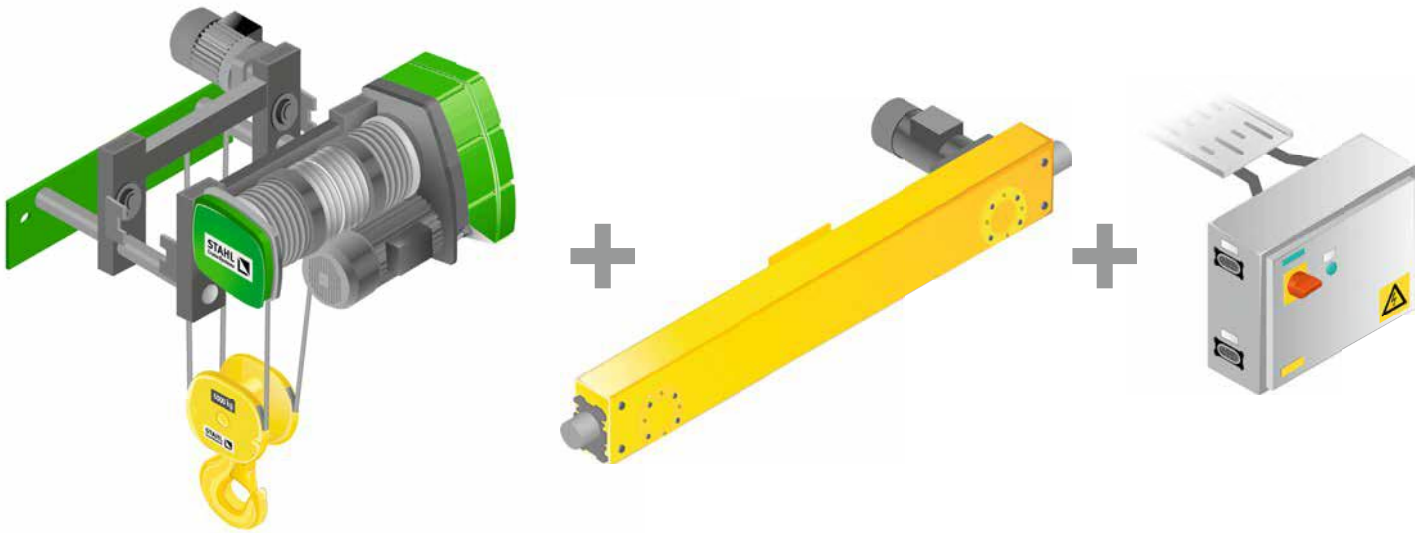

The CraneKit comprises modules from lifting, drive and control technology.

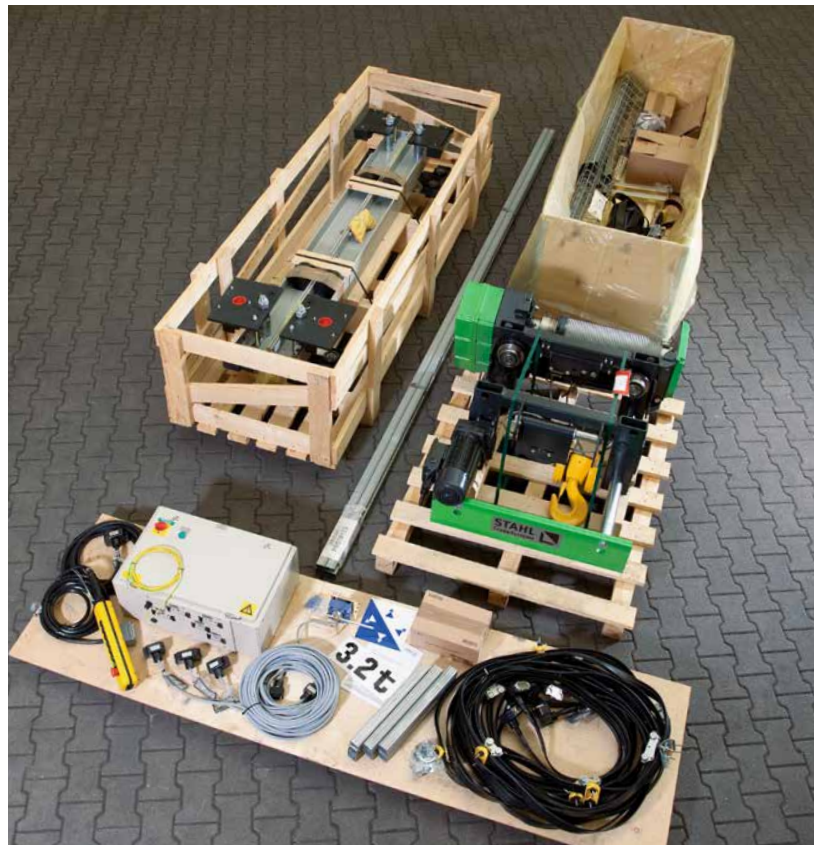

The components are carefully packed and accompanied by all necessary documentation and assembly instructions.

# The CraneGuide



STAHL CraneSystems presents the CraneGuide, a new, intuitive, structured planning software specifically for crane manufacturers. The program permits access to our entire standard product range. You can always find the optimum solution for your customers in the regularly updated CraneGuide database. Project planning for crane systems couldn't be more convenient.

In the CraneGuide you define the design parameters and requirements in input masks and are automatically presented with the matching crane technology components. You can judge right away what the system will look like in 2D or 3D visualisation. You receive precise information on technology and prices and can calculate your crane system whenever you want and on the basis of your individual terms of supply. This is of course also possible offline to a certain extent, however quotation drawings can only be drawn up online.

The information and specifications can be exported as a Word file and then edited. Simply integrate the data into your quotation, make use of it for order acknowledgements or data sheets with drawings and illustrations.

Do you have any questions? Would you like your planning to be checked by our experts or to ask for our advice? It's no problem. You can transmit your planning data via Internet to STAHL CraneSystems where an engineer will deal with it and contact you.

When your planning is completed, the order placed and the data transmitted to STAHL CraneSystems, all you have to do is wait for your individually assembled CraneKit to be delivered.

You can export the quotation as a Word file, edit it and then integrate it into your general quotation.

## The facts

- Structured and intuitive
- 2D and 3D visualisation
- Precise information on technology and price
- Data export in customary formats
- Uncomplicated assistance if you have any queries
- CraneKit supplied directly to you on schedule





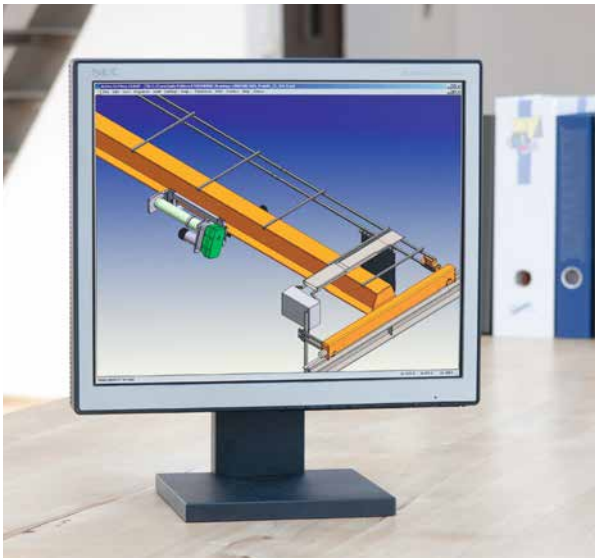
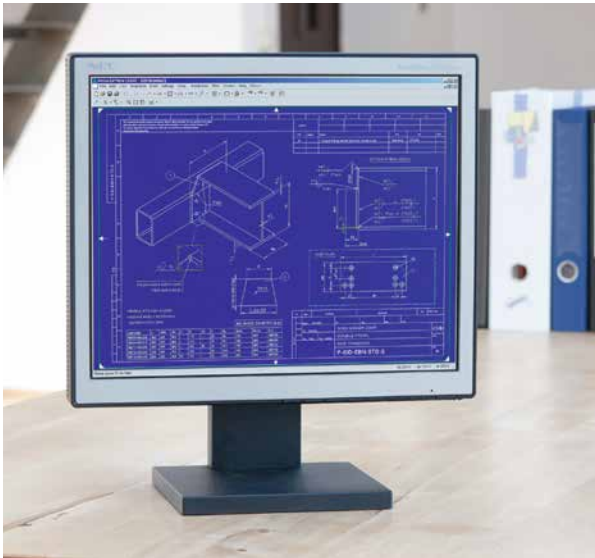

You can define your CraneKit and its components in the clearly laid out form view. After you have configured it, various data sheets and drawings, for example of endcarriage connections, are available. The 3D visualisation of the components selected helps you plan the crane system. The CAD data can be exported for later adaptation.

# The product portfolio



No other manufacturer offers as many hoist variants in different configurations and load capacity brackets, as many off-standard solutions and crane components as STAHL CraneSystems. Technically mature off-standard solutions are continually added to the standard programme by our engineering department in Künzelsau. The short paths between our engineering department and our ultra-modern in-house production contribute intrinsically to the quality of our work. We can respond quickly to unusual enquiries and implement new research findings directly in production. The Twin Drive Concept and the extra-short headroom trolley are just two examples of customised solutions which were such a great success that we have since included them in our standard programme. The development and manufacture of all STAHL CraneSystems products are subject to strict quality assurance management.

As world market leader for explosion-protected crane technology we also offer our hoists and components in explosion-protected design for Zone 1, Zone 21 and Zone 22 with ATEX and IECEx certification.

## The facts

- The world's largest complete product range of hoists and crane components
  - World market leader for explosion-protected hoists and crane components
  - Technically mature off-standard hoists and customised solutions
  - Fast, individual hoist production in Europe
  - Largely maintenance-free components
  - Low wear, long service life in accordance with FEM
  - Optionally available in explosion-protected design complying with ATEX and IECEx
- Please ask for our brochures on: chain hoists, wire rope hoists, winches, crane components.

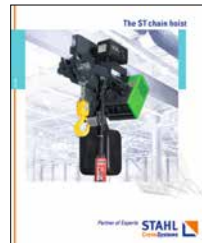
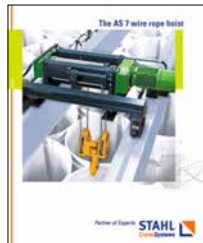

## The wire rope hoist programme

The attractive design of STAHL CraneSystems' wire rope hoists masks a compact, sturdy construction which is largely low-maintenance. They are reliable, powerful and long-lived.

These adaptable wire rope hoists are of uncompromisingly modular design and constructed for the load capacity range from 500 kg to 160,000 kg.

The versatile SH series is available in five frame sizes with 26 load capacity variants for the load capacity range from 500 kg to 25,000 kg. The upper load capacity range up to 100,000 kg is covered by the field-proven AS model. The SHW/SW winch programme extends the field of applications to the heavy load range up to 160,000 kg. Their modular design facilitates cost-efficient off-standard applications and customised solutions.

All wire rope hoists are available in explosion-protected design complying with ATEX and IECEx.

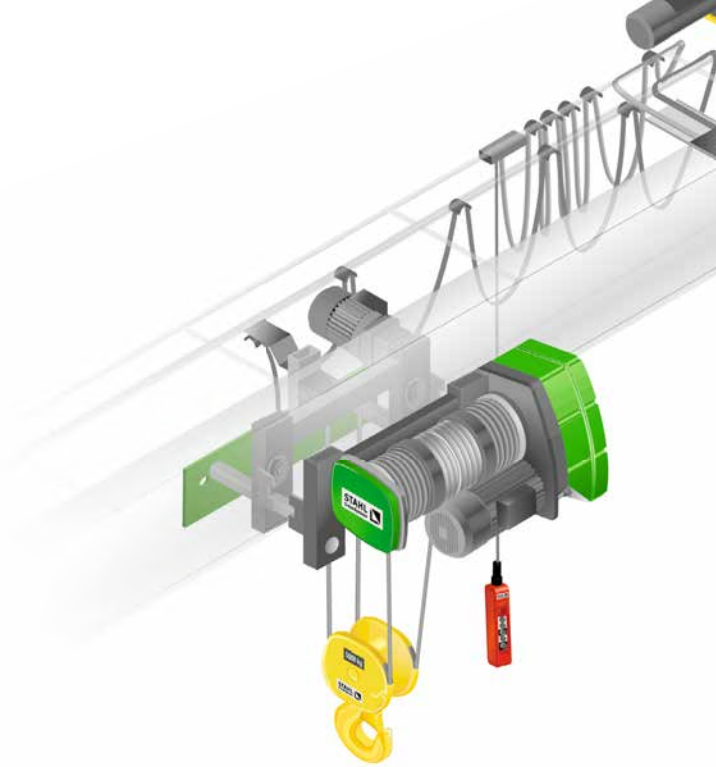

- Standard
- Option

Type	Load capacity up to [kg]	Stationary	OE double rail crab	monorail trolleys		
				KE	UE	DKE
SH 3	3,200	■	■	■	■	■
SH 4	6,300	■	■	■	■	■
SH 5	10,000	■	■	■	■	■
	12,500	■	■	■	■	□
SHR 6	16,000	■	■	■	■	□
SH 6	25,000	■	■	□	■	□
AS 7	80,000	■	■	□	□	□
AS 7 ZW	125,000	■	■	□	□	□
SW 10	100,000	■	■	□	□	□
SW 16	160,000	■	■	□	□	□

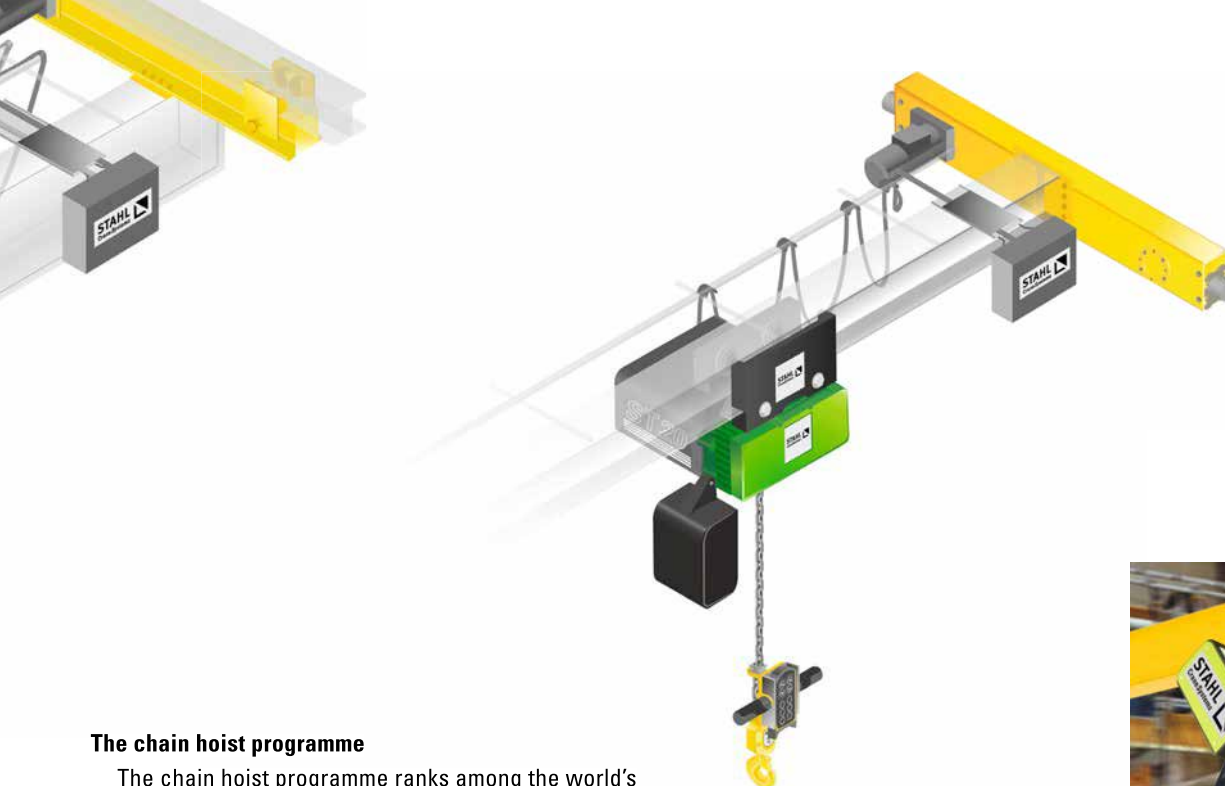

### The chain hoist programme

The chain hoist programme ranks among the world's most distinctive and extensive ranges. The hoists are robust, reliable and largely maintenance-free. The innovative and pioneering chain hoist design brings considerable economic advantages and is particularly suitable for rugged use in industry.

The ST range with 13 load capacity variants from 125 kg to 6,300 kg, three frame sizes and various suspensions permits countless possible combinations. These regularly generate new, practical off-standard designs, for example the dual chain hoist with fixed or variable distance between hooks.

All chain hoists are available in explosion-protected design complying with ATEX and IECEx.



■ Standard  
□ Option

Type	Load capacity up to [kg]	Stationary	Push trolley	Electric trolley	Articulated trolley	Short headroom trolley	Extra-short headroom trolley	Dual chain hoists	
								STD	STD Vario
ST 05	125 – 630	■	■	■	■	■	■	■	□
ST 10	500 – 1,000	■	■	■	■	■	□	■	□
ST 20	1,000 – 2,000	■	■	■	■	■	□	□	□
ST 30	1,250 – 3,200	■	■	■	■	■	■	■	□
ST 50	2,500 – 5,000	■	■	■	■	■	■	■	□
ST 60	3,200 – 6,300	■	■*	■	■	■	□	■	□

\* The ST 60 is only available with 1/1 reeving in the standard programme.



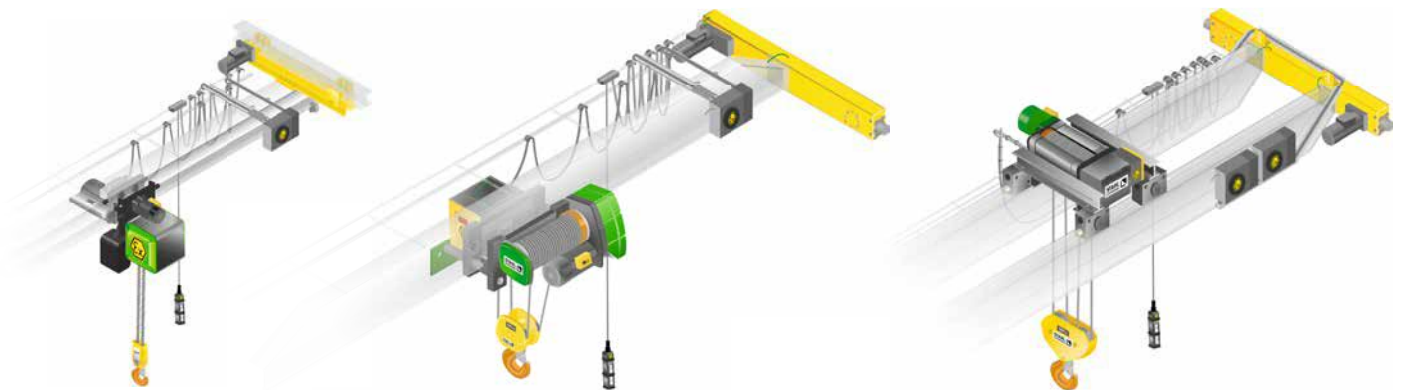
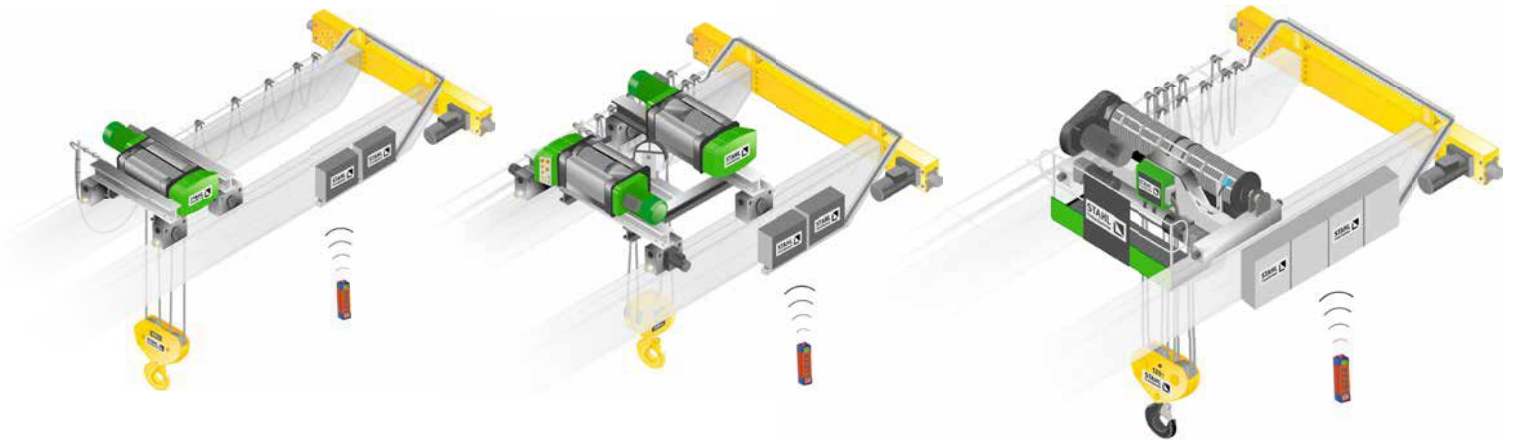
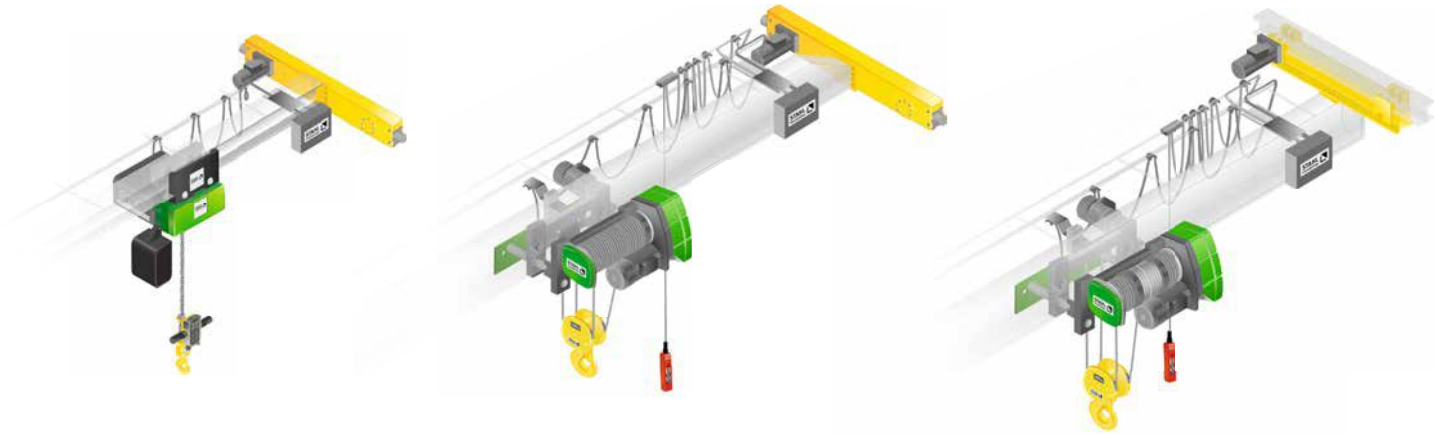

## The electrical components

Standard contactor controls for all customary control voltages are available for the CraneKit. All significant components are supplied with plug connections as far as this is technically possible and meets the project requirements. You can however supplement the standard equipment of your individual CraneKit with convenient accessories. You can choose from various control and monitoring components and optional frequency inverters for hoists and travel drives. This supplementary equipment increases safety in material transport and extends the life of the system.

### Radio remote control units



- Micron push-button transmitter with belt clip, as an option signal feedback from crane
- Spectrum joystick transmitter with harness
- Automatic battery chargers with replacement batteries

### Control pendant



- Robust control pendant with EMERGENCY STOP palm button and control cable
- Two-step switching elements for hoist, cross and long travel
- IP 65 protection
- Additional buttons, for example to activate a horn, can easily be fitted.
- Optional load display. All data displayed can be read out on a notebook with the aid of the SMC Multicontroller.

### SMC Multicontroller and SSC cumulative load control



#### SMC Multicontroller

- Continuous load monitoring by overload cut-off even if hoist is idling
- Monitoring of motor temperature for hoist and travel motors
- Operating data registration, e.g. operating hours, load spectrum, motor switching operations and load cycles
- Data exchange with PC possible

#### SSC cumulative load control

- Load control by overload cut-off, increased safety when operating with more than one load hook
- Maximum of four separate loads can be registered
- Individual loads are measured and hoisting disconnected if the permissible limit load is exceeded

### Overload cut-off



- Load measured at rope anchorage, LET overload cut-off
- Load measured at gear torque support, LEI overload cut-off
- Mechanical load measurement at rope anchorage
- Data evaluation by SLE, SMC or SSC
- The ST chain hoist has an adjustable slipping clutch

### Hoist limit switch



#### Wire rope hoist

- In standard version, the hoist is equipped with a gear limit switch for top and bottom hook position and an operational limit switch for top hook position
- As an option, up to eight switching elements can be fitted to the switch. This permits for example further stopping positions and operational limiting in bottom hook position.

#### Chain hoist

- Cut-off in top hook position or cut-off in top and bottom hook position
- As an option, the chain hoist can be equipped with a gear limit switch with up to eight switching elements.

### Travel limit switches for cross and long travel



- ›Fast/slow‹ changeover (pre-switching) and limiting in both directions of travel
- Obstacle avoidance, with approach from one or both directions of travel
- IP 66 protection

### Load display



- SLD four-digit 7-segment load display (Stahl Load Display), large format, luminous red, available with various interfaces including CAN.
- Choice of 60, 100 or 150 mm digit height
- No additional sensor is required as the standard load sensor is used.

### Signal transmitters



- Visual and acoustic signal transmitters such as horn and flashing light can be mounted on travel carriages.
- The signal transmitters can be activated by a button on the control pendant.

### The endcarriages and travel drives

The robust crane endcarriages from STAHL Crane-Systems are manufactured in modern series production. They can be mounted both on suspension cranes (underslung cranes) and overhead travelling cranes; adjusting them to the crane runway profile is simplicity itself. The wheels in high-quality self-lubricating spheroidal graphite cast iron are available in various diameters. Buffer stops are supplied as standard.

Set your crane in motion. The precisely controlled travel drives make fast, accurate positioning of the load without load swing possible. The integrated centrifugal mass and low-noise gears allow for smooth starting, steady acceleration and gentle braking. They thus ensure a high degree of safety in operation and a long service life.

### Endcarriages for overhead travelling cranes



- 7 different wheel diameters from 90 mm to 500 mm
- Spans up to 40 m
- Load capacity from 125 kg to 50,000 kg

### Endcarriages for suspension cranes



- 3 different wheel diameters from 80 mm to 125 mm
- Spans up to 28 m
- Load capacity from 125 kg to 10,000 kg

### Frequency inverters for ›hoisting‹ and for ›cross and long travel‹



- Extension of system life through stepless acceleration and braking
- Minimum load swing thanks to smooth starting and braking characteristics

### Crane travel drives



- Low-maintenance crane travel drive
- Two-speed as standard in a ratio of 4:1 or stepless frequency control in a ratio of 1:10
- Integrated disc brake



### Expertise in explosion protection

STAHL CraneSystems is known internationally as an explosion protection specialist and is regarded as world market leader in explosion protection technology.

The safety of people and machines in areas subject to gas and dust explosion hazards is our top priority. Here we make no compromises. As developer of numerous innovations in this field we have had palpable influence on crane technology. Experience and know-how from many decades, our own fundamental research and development, approvals from the Federal Physico-Technical Institute (PTB) and other test institutes in many countries emphasise our expertise. Hoisting technology from STAHL CraneSystems ranks among the safest technology on the market in the chemical, petrochemical and pharmaceutical industries, the food processing industry, power supply, shipbuilding, offshore and natural gas liquefaction industries (LNG).

The CraneKit with explosion-protected hoist and crane components, including supplementary equipment, is based without exception on our standard programmes. All components come from our in-house production with certified quality assurance system, from motor and brake to controls and control pendant. For this ensures the complete, high-quality explosion protection on which users, crane manufacturers and system manufacturers all over the world have relied for decades. The strict ATEX directives and IECEx regulations on mechanical and electrical explosion protection are of course met.

### The facts

- Internationally leading specialist for explosion protection technology
  - One of the world's most comprehensive product portfolios for Zone 1, Zone 2, Zone 21 and Zone 22
  - All equipment available in explosion-protected design
  - Design and maintenance to ATEX and IECEx in certified quality
- Please ask for our brochure with fundamental information on expertise in explosion protection.







Use	Category	Protection against	Explosion protection class
<b>Zone 1</b>	Ex II 2 G	Gas	Ex de IIB T4 or Ex de IIC T4
<b>Zone 2*</b>	Ex II 3 G	Gas	Ex de nA IIB T3 (T4) or Ex de nA IIC T3 (T4)
<b>Zone 21</b>	Ex II 2 D	Dust	Ex tD A21 IP 66 T 120 °C
<b>Zone 22</b>	Ex II 3 D	Dust	Ex tD A22 IP 66 T 120 °C

\* The Zone 2 version is only available as standard in the wire rope hoist programme.

# Erection



Your individual CraneKit from STAHL CraneSystems comprises crane components for underslung, bridge, single girder or double girder overhead travelling cranes. Every single component is manufactured to a high standard of quality and exhaustively tested before being meticulously packed. Erection is user-friendly, conveniently arranged and based on the plug and play principle. The straightforward, detailed erection instructions are a great help. Some components are supplied pre-assembled and need only be pushed in and bolted. Cables are mounted on the cable trolleys. As far as it is technically possible and meets the application conditions, all cables are supplied with plugs, and all connections are clearly labelled. This not only saves you valuable time but reassures you that everything is correct.

And if you should ever need our help during erection, the STAHL CraneSystems factory service centre will attend to you immediately.

## The facts

- Detailed erection instructions
- Pre-assembled components
- Plug and play: all cables are supplied with plugs as far as is technically possible
- All connections are labelled
- Cables already mounted on cable trolleys
- Time-saving final erection
- Assistance for difficult erections







## A capable partner



STAHL CraneSystems is the partner of experts and supplies first-class hoists and crane components solely to crane manufacturers. Our CraneKit is however not just a box of components. We accompany and assist you in your work as you find appropriate. That is unmistakably STAHL CraneSystems. You can ask for and draw on our assistance during the whole project whenever you need it. In this way you are in a position to take on even challenging projects or elaborate customised solutions.

Over 130 years of practical approach and experience and the constant drive to invention and development characterise our history. We have played a decisive role in developing the industry in many fields. Today we are one of the world's leading brands and the major manufacturer of explosion-protected hoists and crane components. Chain hoists, wire rope hoists, winches, drive and control technology, condition monitoring systems; technically and economically, STAHL CraneSystems' products rank in the premium class at international level. We relay our specialist knowledge directly to our customers in the form of our liberal consulting services.







**The crane manufacturer on the ground advises and sells**

**We support you with**

- Seminars: knowledge of the technology and the products is essential if you want to give comprehensive advice. In our seminars you will learn everything you need to provide expert consultation.
- Advertising: our informative product brochures underline your expertise.
- Brand management: in particular as a small or medium-sized crane manufacturing company you will profit from STAHL CraneSystems' global marketing activities.



**The crane manufacturer on the ground develops and designs**

**We support you with**

- Engineering: our professional project team assists you in planning ambitious projects. You can thus take on lucrative orders for customised cranes which you might not be able to master without assistance.
- Expert knowledge: you can rely on our experience for orders in explosion-risk areas. The engineering team will advise and assist you with regard to all relevant safety questions and specific approvals.



**The crane manufacturer on the ground produces**

**We support you with**

- CraneKits: you build the system, we supply the technology pre-assembled, ready wired and ready for use; whether you decide on a standard hoist from the world's largest range or on a customised design which we manufacture specially for you.
- CraneKits with explosion-protected technology: what you need to know: only STAHL CraneSystems offers CraneKits all over the world with one of the largest product portfolios of explosion-protected hoists and crane components.



**The crane manufacturer on the ground erects and repairs**

**We support you with**

- Factory service centre: are you faced with a difficult erection or a tricky problem? Our factory service centre is at your service around the clock and is ready to offer you practical help and advice if you are at a loss.
- Workshops: your fitters need to be fully familiar with the crane technology. This is why in our workshops we train them to work with STAHL CraneSystems products. Our commitment to quality extends not just to our support, but to you yourselves too.

Argentina Australia Austria Belgium Brazil Canada Chile **China** Columbia Croatia Czech Republic  
Denmark Ecuador Egypt Estonia Finland **France** Germany **Great Britain** Greece Hongkong Hungary **India** Indonesia

Ireland Israel Italy Jordan Latvia Lebanon Lithuania Malaysia Mexico  
Netherlands Nigeria Norway Pakistan Peru Philippines Poland **Portugal** Rumania Russia

**Singapore** Slovakia Slovenia South Africa South Korea **Spain** Sweden Syria  
Taiwan Thailand Turkey **UAE** Uruguay **USA** Venezuela Vietnam

Sales partners **Subsidiaries**

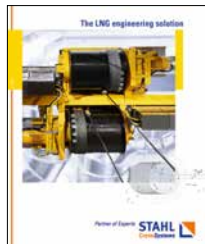
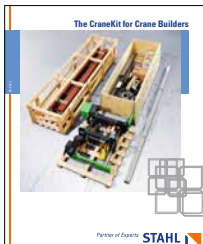
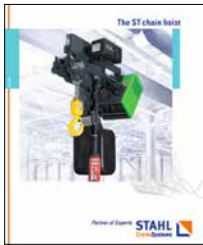

Presented by

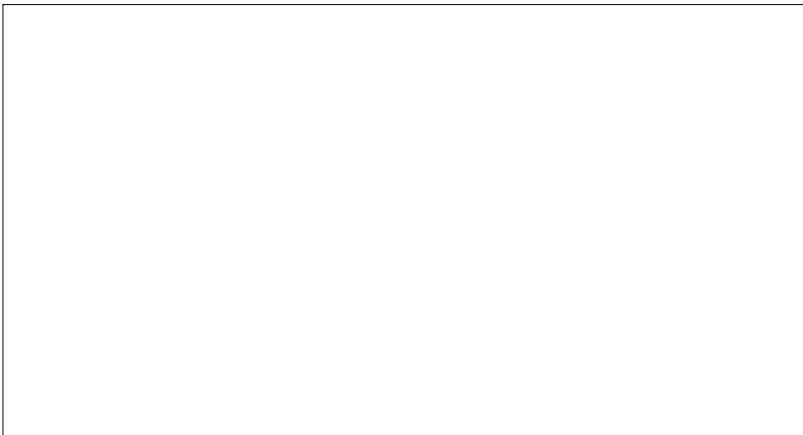

→ [www.stahlcranes.com](http://www.stahlcranes.com)

STAHL CraneSystems GmbH  
Daimlerstr. 6, 74653 Künzelsau, Germany  
Tel +49 7940 128-0, Fax +49 7940 55665  
marketing@stahlcranes.com

*Partner of Experts*

